

MANIFOLDS MAGNETIC FILTER

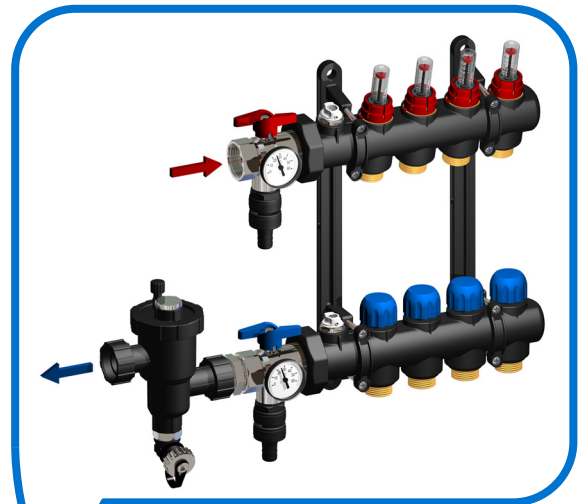

NEW
2021



F71 is the new magnetic dirt separator designed specifically for radiant systems, to be housed directly on the return manifold; the combined action of a magnet and a filter allow you to separate the impurities present in the water; laboratory tests have shown the particular effectiveness against ferrous particles, often resulting from radiators connected to the low temperature system. After the simple removal of the magnet, the residues can be easily removed through the special drain valve. The small size of F71 allows installation with any manifold, even in a box, with a minimum depth of 80 mm.

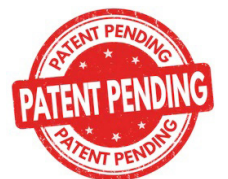
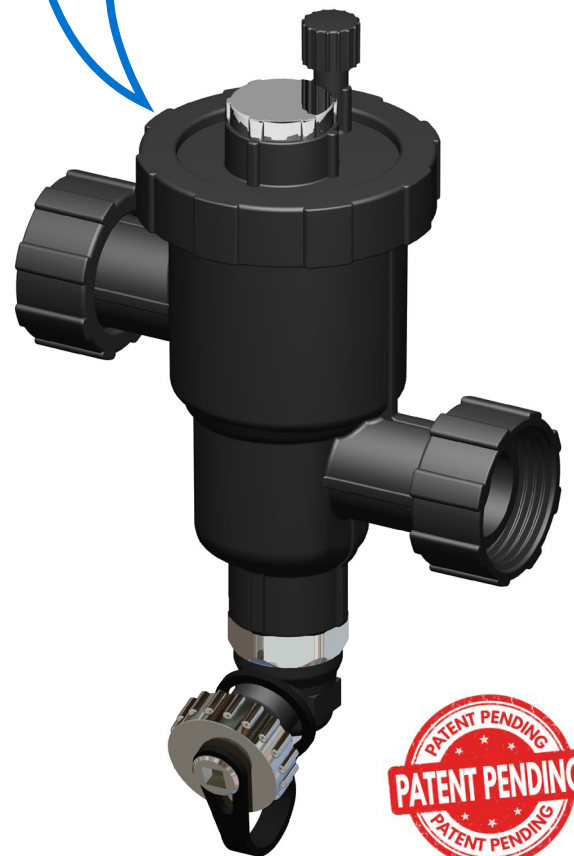

Advantages:

- Extremely compact product, specifically designed to be installed with any type of manifold for radiant systems (depth 80 mm.)
- Drain valve to easily eliminate intercepted residues without having to act on the entire system.
- Constant Kv and irrelevant pressure drops.
- Easily removable for cleaning in all its parts.
- Immediate extraction of the magnet from its body.
- Centrifugal and cyclonic operation that allows impurities to concentrate on the magnet and on the external walls of the dirt separator.

TECHNICAL FEATURES

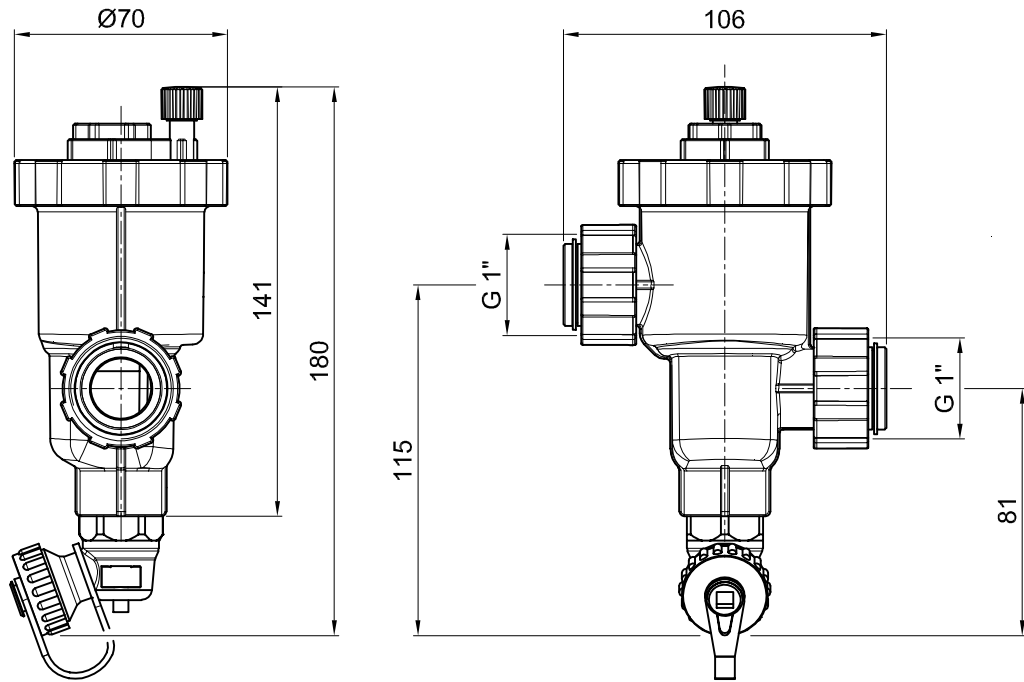

N.	ITEM	MATERIAL
1	Lock plate nut	Polyamide PA66+30% glass
2	Brass cap	Nickel-plated brass CW614N
3	Magnet	Neodymium
4	Filter cap with air vent	Polyamide PA66+30% glass
5	Filter	Acciaio inox AISI 304L
6	O-ring	NBR 70 SH
7	Filter body	Polyamide PA66+30% glass
8	1" nut	Polyamide PA66+30% glass
9	Stop rings	Carbon steel
10	Drain valve	PA6+30% glass / CW617N

TECHNICAL DATA	
Inlet connection	1" F
Outlet connection	1" F
Drain valve connection	1/2" F
Stop rings	25,5x2,30x1,5
Lock plate nut	M63x1,5
Plate O-ring	52,07x2,62
Magnet	REN 35 B 11.500 Gauss
Filter	Wire mesh R4x2 Filtration 1200 µm
Working pressure	max 10 bar
Working temperature	4+70°C

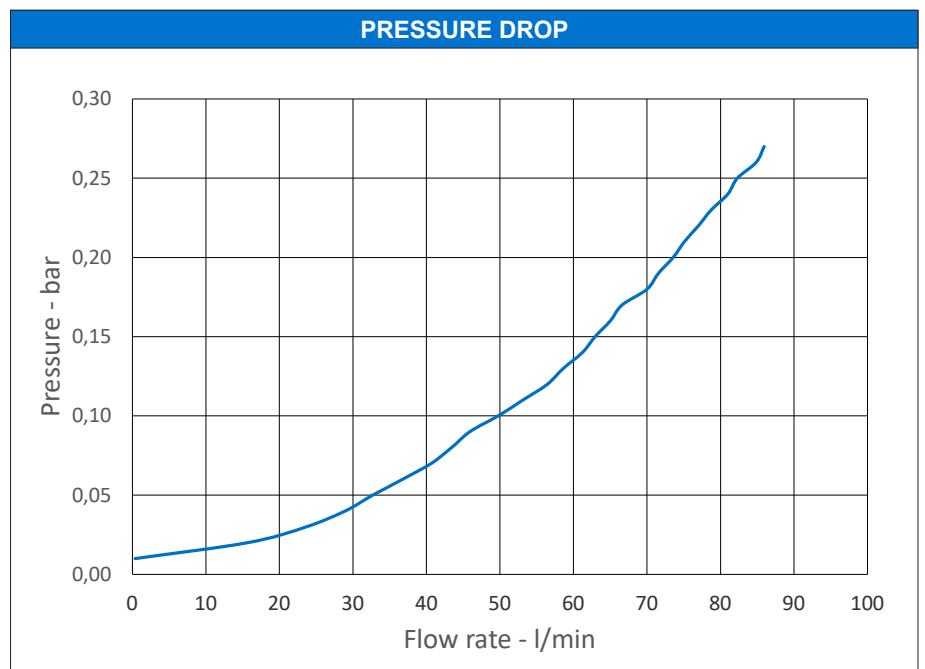
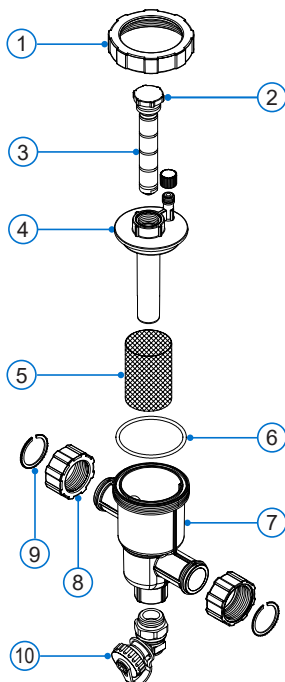

ONDA THERM SRL

Administrative Department: Via G. Verdi, 38/B - 24060 Telgate (BG) - Italy ☎ +39 035 0591003 ✉ info@ondathermsrl.com 🌐 www.ondathermsrl.com
Headquarter: Via Monte Fenara, 11 - 13018 Valduggia (VC) - Italy ☎ +39 0163 487 731